

***sf 50***

*2" Saniflux Pump*

***EOM***

*Engineering Operation  
& Maintenance*

AN

**OSCILLATING** TECHNOLOGY

THAT SHRIVELS YOUR COST OF OWNERSHIP



**saniflux**  
THE SANITARY SERIES hygiene Your PROCESS



hygienic Solutions

ASSEMBLY / DIS-ASSEMBLY  
ON-THE-SPOT

LOVE

FOOD

hate waste

**neoflux**<sup>TM</sup>  
Hallmark of Excellence

*Hygiene Your Process*

**WARNING/CAUTIONS:**

Read all these **SAFETY INSTRUCTIONS** BEFORE installing or using this equipment. Keep this manual handy for reference/training.

## CONGRATULATIONS...

When you purchased your new *Neoflux* Air-Operated Diaphragm Pump, you bought a dependable and quality-built product. The **sf** series of Diaphragm Pumps manufactured by *Neoflux*, and the range of options and materials, should satisfy nearly every hygiene industrial pump need.

This owner's manual is intended as a guide for proper installation, operation and maintenance to keep your Diaphragm Pump operating safely and efficiently on the job. Assembly and Disassembly information is also included for your benefit.

Sincerely,

*Atit Shah*  
Director  
*Neoflux Technic Pvt. Ltd.*



### Halogenated Solvents Warning:

Halogenated solvents can, under certain circumstances, corrode aluminum or galvanized parts. If the wetted parts or a pressurizable fluid system contain aluminum or galvanized parts, this corrosive action could cause an **EXPLOSION**. Although manufacturers of these solvents typically add inhibitors, there is no known inhibitor that will prevent the corrosive reaction under ALL circumstances.

Special caution should be exercised handling reclaimed or used solvents since the inhibitors are often degraded. ONLY stainless steel or PVDF pumps should be used for these materials. Typical examples of halogenated hydrocarbon solvents (H.H.C.) include, but are not limited to, the following: Trichlorethane, Trichlorethylene, Methylene Chloride, Methyl Chloride, Carbon Tetrachloride, Chloroform and Dichlorethylene.



## TABLE OF CONTENTS



• <b>Cautions – READ FIRST!</b>	<b>4</b>
• <b>Neoflux Pump Designation System</b>	<b>5</b>
• <b>The Neoflux Pump</b>	
▪ About AODD Pump	<b>06</b>
▪ Principle Of Operation – How it works	<b>07</b>
▪ Air Distribution System	<b>08</b>
▪ Air Adjustment Knob	<b>09</b>
• <b>Dimensional Drawings</b>	<b>10</b>
• <b>Technical Specs &amp; Performance Curve</b>	<b>11</b>
• <b>Installation &amp; Operation</b>	
▪ Installation & Site Selection	<b>12</b>
▪ Submersible Application	<b>14</b>
▪ Viscous Fluid Application	<b>15</b>
▪ Suction & Discharge Piping	<b>16</b>
▪ Pump Handling & Commissioning	<b>18</b>
▪ Operation & Maintenance ( <i>Inspection &amp; Noise Hazard</i> )	<b>19</b>
• <b>Troubleshooting</b>	<b>20</b>
• <b>Disassembly / Reassembly Directions</b>	<b>22</b>
• <b>Pump CIP Directions</b>	<b>30</b>
• <b>Diaphragm Pump Storage / Recommended Spare Part List</b>	<b>31</b>
• <b>Diaphragms &amp; Other Elastomers Storage Recommendations</b>	<b>32</b>
• <b>Exploded View</b>	<b>33</b>
• <b>Parts Listing</b>	<b>34</b>
• <b>Elastomeric Options</b>	<b>35</b>
• <b>Warranty</b>	<b>36</b>
• <b>Neoflux Design Platform</b>	<b>37</b>
• <b>Neoflux Air-Distribution Systems</b>	<b>38</b>
• <b>AODD Pump Selection</b>	<b>39</b>
• <b>Pump Wetted Material Compatibility Chart</b>	<b>40</b>
• <b>General Diaphragm Selection Guide</b>	<b>41</b>
• <b>Service / Maintenance Log</b>	<b>42</b>
• <b>Declaration of Conformity</b>	<b>43</b>
• <b>Contact Neoflux</b>	<b>44</b>



**READ FIRST!**



Please consider following points during Installation, Inspection, Repairing and Re-Assembling the pump.

- Do not apply compressed air to the exhaust port— pump will not function.
- Do not; under any circumstance loosen the set screw located at the adjuster dial of the *sf 50* model pump. If the set screw is loose when the pump is pressurized, it could eject and cause injury to anyone in the area.
- Always wear safety glasses when operating pump. If Diaphragm rupture occurs, material being pumped may be forced out from air-exhaust.
- Do not exceed 8.6 bar (125 psig) air supply on *sf 50* models. 
- Do not exceed 75°C (167°F) Air Inlet temperature.
- Tighten all clamps prior to installation. Fittings may get loose during transportation.
- Pumps should be thoroughly flushed before installing into process lines. FDA approved pumps should be cleaned and/or sanitized before being used.
- The process fluid and cleaning fluids must be chemically compatible with all wetted pump components. Consult *Neoflux* for details.
- Prevention of static spark – If static sparking occurs, fire or explosion could result. Proper grounding of pump, valves & containers is critical when handling flammable fluids or whenever discharge of static electricity is a hazard. 
- Before any repair or maintenance is attempted, the compressed air line to the pump should be disconnected & all air pressure allowed to bleed from pump. Disconnect all intake, discharge & air lines. Drain the pump by turning it upside down & allowing any fluid to flow into a suitable container.
- Blow out air line for 10 to 15 seconds before attaching to pump to make sure all pipe line debris is clear. Use an in-line air filter. A 5 $\mu$  (micron) filter is recommended.
- When installing diaphragms, it is important to tighten outer pistons simultaneously (turning in opposite directions) to ensure tight fit.
- Do not lubricate air supply – lubrication will reduce pump performance. All *Neoflux* Air-Distribution Systems are Lube-Free. Pump is already pre-lubed.
- When removing the end-cap using compressed air, the air valve end-cap may come out with considerable force. Hand protection such as a padded glove or rag should be used to capture the end-cap.
- Do not over tighten the air inlet reducer bushing. Additionally, too much torque on the muffler may damage the air valve muffler plate.

Grounding  
Symbol



# NEOFLUX PUMP DESIGNATION SYSTEM

## sf 50 – 2" The Sanitary Pump

**Maximum Flow Rate:** UPTO 581 LPM (153.8 GPM) (34.8 M<sup>3</sup> / Hr.) (Pressure Ratio – 1:1)

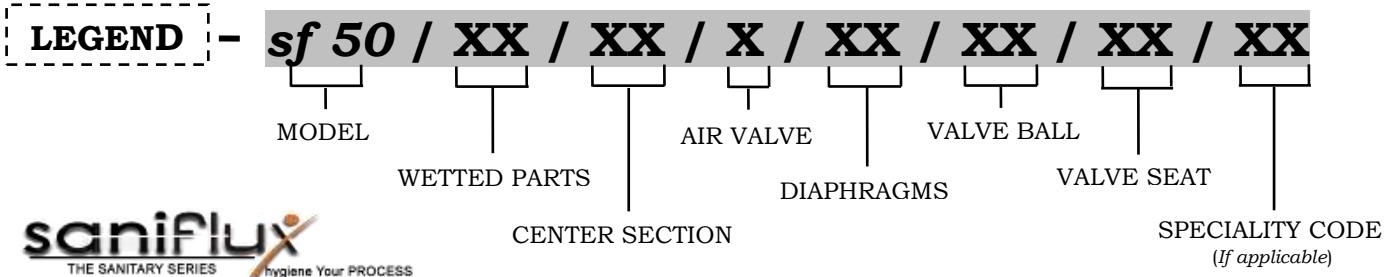

**Type of Device:** Air-Operated Double Diaphragm Pump

Your Pump Model –

### Material Codes:

**MODEL:**

sf 50 = Neo-Tune

**AIR VALVE:**

AA = Aluminum  
PP = Polypropylene

**VALVE BALL:**

BN = Buna-N (Red Dot)  
EP = EPDM  
NE = Neoprene  
VT = Viton (Green Dot)  
PU – Polyurethane (Clear)  
PT – PTFE (White)

**WETTED PARTS:**

SS = Electro - Polished  
Stainless Steel 304 / 316L

**DIAPHRAGMS:**

BN = Buna-N (Red Dot)  
EP = EPDM (Ethylene Propylene Diene Monomer)  
NE = Neoprene  
VT = Viton (Green Dot)  
PU – Polyurethane (Clear)  
PT – PTFE w/Neoprene Back-up

**VALVE SEAT:**

AL – Aluminum  
SS – Stainless Steel  
PP - Polypropylene  
BN = Buna-N (Red Dot)  
NE = Neoprene  
VT = Viton (Green Dot)

**CENTER SECTION:**

AA = Aluminum  
SS = Stainless Steel  
PP = Polypropylene

### Other Details:

**Temperature Limitations:** Refer to Page # 35

Please refer to Page # 43 of this Engineering, Operation & Maintenance manual (EOM) for information of your specific Pump Model, Serial Number and Manufacturing Date.

Pump Model & Serial Number is also located on your pump's Serial Tag. This Serial Tag is tangled on the Discharge (Top) Manifold of all Neoflux make pumps.

*Note:* Most elastomeric materials use Colored Dot for identification.

# sf 50 – 2" The Sanitary Pump

## About Air-Operated Diaphragm Pump

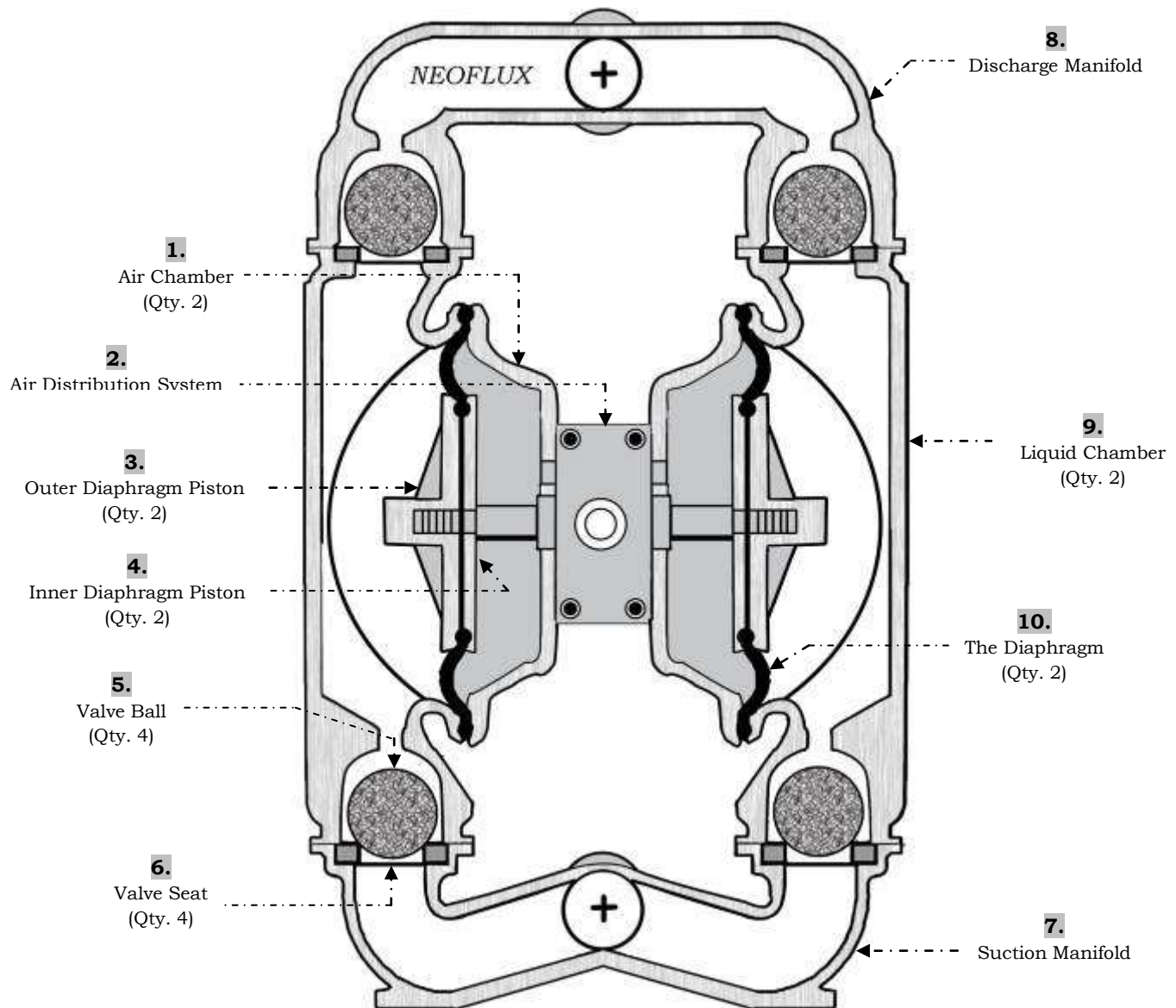

1. **Air Chamber** – These chambers houses the air which powers the diaphragms.
2. **Air Distribution System** – The Air Distribution System is the most important part of the pump. It has a mechanism that shifts the pump in order to create suction & discharge strokes.
3. **Outer Diaphragm Piston** – These pistons provide a means to connect the diaphragms to the reciprocating common shaft & to seal the liquid side from the air side of the diaphragm.
4. **Inner Diaphragm Piston** – These pistons are located on the air side of the pump and do not come into contact with the process fluid.

5. **Valve Ball** – *Neoflux* air-operated diaphragm pumps use suction & discharge check valves to produce directional flow of process fluid in the liquid chamber. The check valve balls seal & release on the check valve seats allowing for discharge & suction of process fluid to occur.
6. **Valve Seat** - The removable seats provide the ball valves a site to check.
7. **Suction Manifold** – Process fluid enters the pump from the intake port located on the suction manifold at the bottom of the pump.
8. **Discharge Manifold** - Process fluid exits the pump from the discharge port located on the discharge manifold at the top of the pump.
9. **Liquid Chamber** - The liquid chamber is filled with the process fluid during the suction stroke and is emptied during the discharge stroke
10. **The Diaphragm** - The diaphragm membrane provides for separation of the process fluid and the compressed air power source. To perform adequately, diaphragms should be of sufficient thickness and of appropriate material to prevent degradation or permeation in specific process fluid applications. *Neoflux* offers a variety of diaphragm materials for your specific application requirements. Turn to the elastomers section for more details.

### Principle of Operation - PUMP

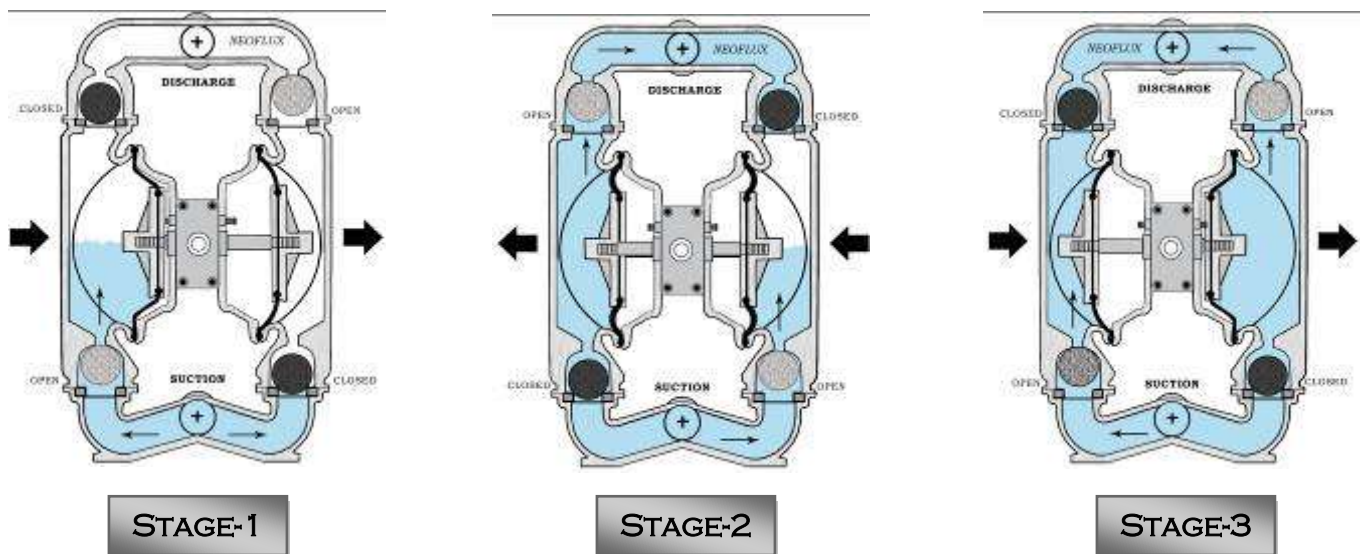

**Neoflux** Diaphragm pump works with the compressed air coming from compressor. They are common industrial pumps that use positive displacement to move liquids. These devices typically include a Two Diaphragms and Liquid Chambers, as well as suction and discharge check valves to prevent backflow. Pistons are coupled to the diaphragm.

Diaphragm pumps are highly reliable because they do not include internal parts that rub against each other. In fact, prolonged diaphragm life may be possible if the diaphragm pump is run dry to prime. Typically, wear on the diaphragm is due to the corrosive properties of media fluids or gases and/or excessive air supply pressures.

### Function of an AODDP:

- This pump uses a very simple valve system to move the DIAPHRAGM SHAFT. The flexible diaphragms are round disks attached at each end of the common shaft.
- The PILOT SPOOL is pushed back and forth whenever the Diaphragm Shaft reaches the end of its throw. The Pilot Spool allows air to move the Air Distribution Valve back and forth.
- The AIR DISTRIBUTION SYSTEM controls air flow to the left or right air chamber, reversing on each stroke. This action causes the other side to draw product into the pump on a suction stroke.
- The four BALL VALVES are free-floating and operated by pressure differences in the pumped liquid. In the pump, liquid flow is from the bottom to the top.
- The pump may take several cycles to completely prime depending on the conditions of the application.

## Neo-Flo Principle of Operation – Air Distribution System

The **Neo-Flo** air distribution system incorporates 3 moving parts: The Air Valve spool, The Pilot Spool & The Main Shaft. The heart of the system is the air valve spool and air valve. This valve design incorporates an unbalanced spool. The smaller end of the spool is pressurized continuously, while the large end is alternately pressurized then exhausted to move the spool. The spool directs pressurized air to one air chamber while exhausting the other. The air causes the main shaft/diaphragm assembly to shift to one side — discharging liquid on that side and pulling liquid in on the other side. When the shaft reaches the end of its stroke, the inner piston actuates the pilot spool, which pressurizes and exhausts the large end of the air valve spool. The repositioning of the air valve spool routes the air to the other air chamber.

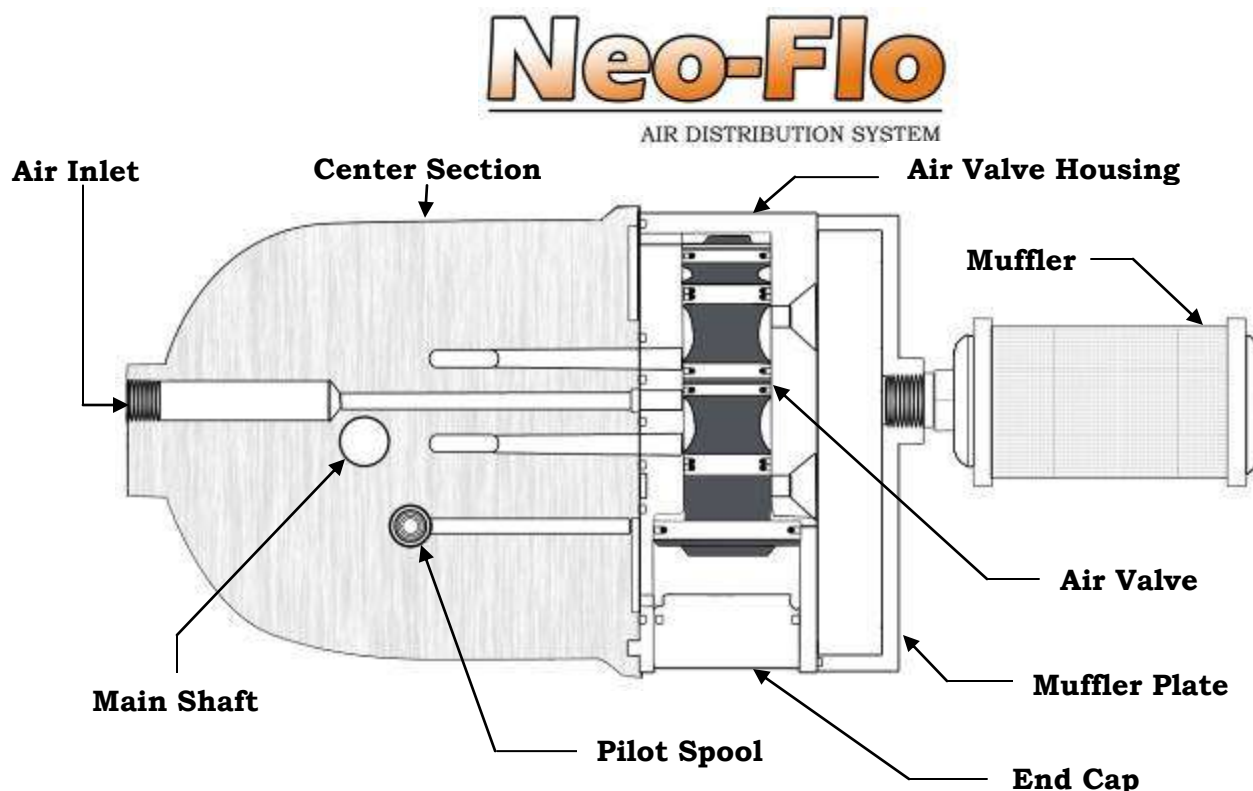



## Neo-Tune Principle of Operation – Air Adjustment Knob

The *Neo-Tune* design really controls the flow you want. With the turn of an integrated control dial, the operator can select the optimal balance of flow and efficiency that best meets the application needs. The knob provides higher performance, lower operational costs and flexibility that exceed previous industry standards.

1. Turning the dial changes the relationship between air inlet and exhaust porting.
2. Each dial setting represents an entirely different flow curve
3. *Neoflux* pumps are shipped from the factory on setting 4, which is the highest flow rate setting possible.
4. Moving the dial from setting 4 causes a decrease in flow and an even greater decrease in air consumption.
5. When the air Consumption decreases more than the flow rate, efficiency is improved and operating costs are reduced.

# Neo-Tune

CONTROL THE FLOW



# sf 50 – 2" The Sanitary Pump

## Dimensional Drawings

**Estimated Ship Weight:**

Stainless Steel..... 50 kg. (110 lb.)

<b>sf 50</b>		
<b>Item</b>	<b>Metric (mm)</b>	<b>Inch</b>
A		
B		
C		
D		
E		
F		
G		
H		
I		
J		
K		
L		
M		
N		
O		
P		
Q		

# sf 50 – 2" The Sanitary Pump

## Technical Specifications

**FLOW RATE TO 581 LPM (153.5 GPM) (34.86 M<sup>3</sup> / Hr.) (Pressure Ratio – 1 : 1)**

**AIR SUPPLY PRESSURE = 2 BAR (29.01 PSIG) to 8.6 BAR (124.7 PSIG)**

• **Port Size – Tri - Clamp Connections (Tri-Clamp Hose fitting Included)**

- Liquid Inlet / Suction Port – 2"
- Liquid Outlet / Discharge Port - 2"
- Air Inlet – ¾" BSP
- Air Exhaust – 1" Female NPT (Includes Neo-Muff Silencer)

**Note:**

Pump incorporated with **Neo-Tef** PTFE Diaphragms will reduce the Output by 37%

**Flow Rate:** 361 LPM (95.4 GPM) (21.7 M<sup>3</sup>/Hr.)

• **Suction Lift**

- **Rubber Diaphragm** *PTFE Diaphragms*
  - Dry – 3.2 meter (10.5 ft.) Dry – 2.4 meter (7.87 ft.)
  - Wet – 9.0 meter (29.5 ft.) Wet – 8.7 meter (28.5 ft.)

- **Maximum Particle Size / Maximum Compressible Solids:** Ball Valve - ½" (12.7mm)  
Flap Valve - 1-5/8" (41.5 mm)

**sf50 – 2" The Sanitary Pump (Max. Cycles & Strokes Table)**

DIAPHRAGMS	Max. Displacement / Stroke	Max. Displacement / Cycle	Max. Strokes / Minute	Max. Cycles / Minute
Rubber Fitted				
PTFE Fitted				

**sf50 – 2" The Sanitary Pump (Recommended Cycles & Strokes Table)**

DIAPHRAGMS	Recommended Strokes / Minute	Recommended Cycles / Minute
Rubber Fitted		
PTFE Fitted		

• **Ship Weight:**

- Stainless Steel 316 ..... 50kg. (110 lb.)
- **Typical Noise Level - 69dB (with Neo-Muff Silencer)**

• **Pump Dimensions - Height 1010mm (40") X Width 472mm (19") X Depth 400mm (16")**

\* Displacement per stroke was calculated at 4.9 bar (71 psig) air inlet pressure against a 2.2 bar (31 psig) head pressure.

### sf 50 Performance Curve

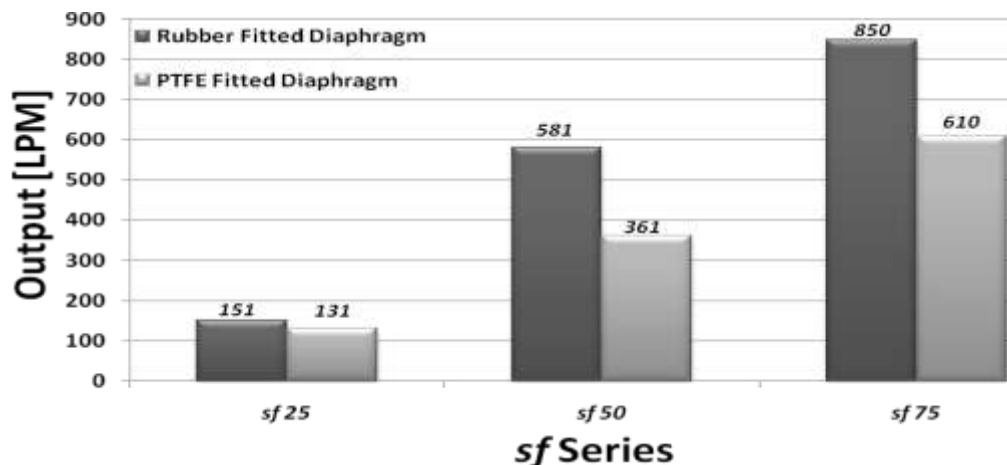

Flow indicates in chart are determined by pumping water with vertically mount position. Based on Specific Gravity of 1.0  
For optimum life & performance, pumps should be specified so that daily operation parameters will fall in the center of the pump performance curve.

## **sf 50 – 2" The Sanitary Pump**

### Suggested Installation

*Neoflux sf 50 Model has a 2" inlet & Outlet & is designed for flows to 581 lpm (153.5 gpm).*

The suction pipe size should be at least the equivalent or larger than the diameter size of the suction inlet if highly viscous material is being pumped. The suction hose must be non-collapsible, reinforced type as the *sf 50* model is capable of pulling a high vacuum. Discharge piping should be at least 2"; larger diameter can be used to reduce friction losses. It is critical that all fittings & connections are airtight or a reduction or loss of pump suction capability will result.

**Location:** Noise, Safety & other logistical factors usually dictate where equipment should be situated on the production floor. Within the framework of these & other existing conditions, every pump should be located in such a way that all the below key factors are balanced against each other to maximum advantage.

**Access:** First, the location should be accessible. If it is easy to reach the pump, maintenance personnel will have an easier time carrying out routine inspections & adjustments. Should major repairs become necessary, ease of access can play a key role in speeding the repair process and reducing total downtime.

**Solenoid Operation:** When operation is controlled by a solenoid valve in the air line, three-way valve should be used, thus allowing trapped to bleed off and improving pump performance. Pumping volume can be set by counting the number of strokes per minute and multiplying by displacement per stroke.

**Sound:** Sound levels are reduced by using the specially designed Neo-Muff element. Other mufflers can be used, but usually reduce pump performance.

**Air Supply:** Each Pump location should have an air line large enough to supply the volume of air necessary to achieve the desired pumping rate. Do not exceed air supply of 8.6 bar (125 psig) depending on the pumping requirement. Remember, more the pressure, more the wear & tear of pump parts and diaphragms. Ideal air pressure should be 4 to 5 bar.

For best results, pumps should use a 5 $\mu$  (Microns) air filter, needle valve and regulator. The use of an air filter before the pump will insure that the majority of any pipeline contaminants/moisture will be eliminated.

**Elevation:** Selecting a site that is well within the pump's dynamic lift capability will ensure that loss-of-prime troubles will be eliminated. In addition, pump efficiency can be adversely affected if proper attention is not given to site location.

**Piping:** Final determination of the pump site should not be made until the piping problems of each possible location have been evaluated. The impact of current and future installation should be considered ahead of time to make sure that inadvertent restrictions are not created for any remaining sites.

The best choice possible will be a site involving the shortest and straight hook-up of suction & discharge piping. Unnecessary elbows, bends & fittings should be avoided. Pipe size should be selected to keep friction losses within practical limits. All piping should be supported independently of the pump. In addition, the piping should be aligned to avoid placing stress on the pump fittings.

Flexible Hose can be installed to aid in absorbing the forces created by the natural

reciprocating action of the pump. If the pump is to be bolted down to a solid location, a mounting pad placed between the pump and the foundation will assist in minimizing pump vibration. Flexible connections between pump and rigid piping will also assist in minimizing pump vibration. If quick-closing valves are installed at any point in the discharge system, or if pulsation within a system becomes a problem, a surge suppressor should be installed to protect the pump, piping and gauges from surges and water hammer.

### sf 50 Performance Bar

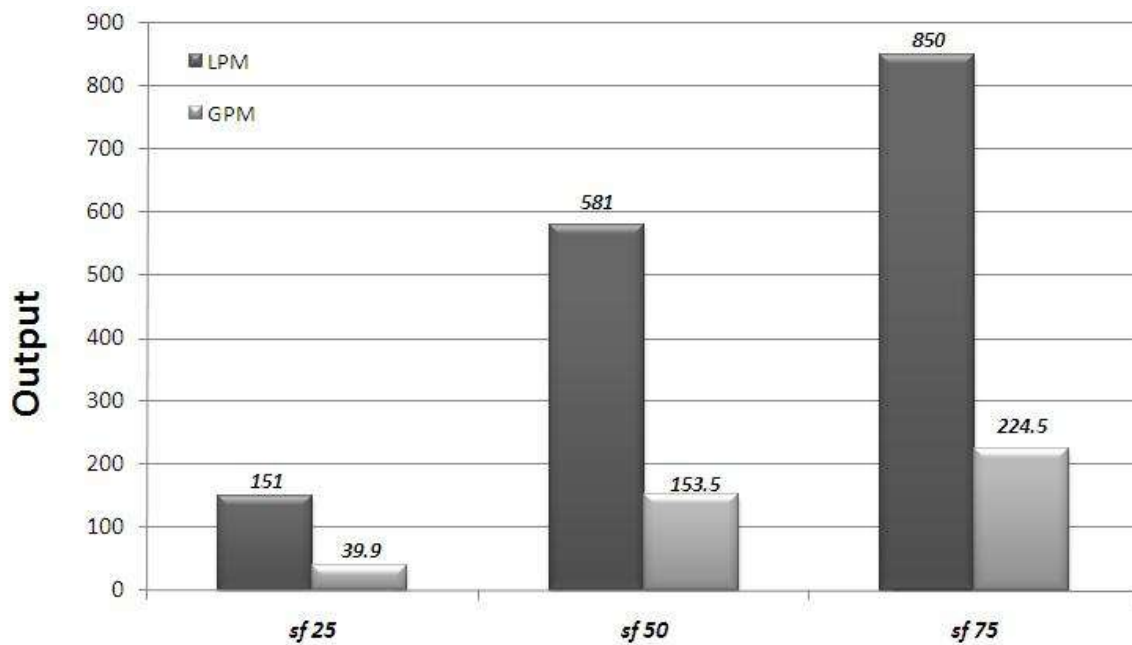

### sf Series - Rubber Fitted Diaphragm

## Submersible Application:

*Neoflux* AODD models can be installed in submersible applications only when both the wetted and non-wetted portions are compatible with the material being pumped. If the pump is to be used in a submersible application, a hose should be attached to the air & pilot spool exhaust ports of the pump. These should then be piped above the liquid level. The exhaust area of the pilot spool is designed to be tapped for a 1/4" BSP fitting which is located below Air Inlet port.

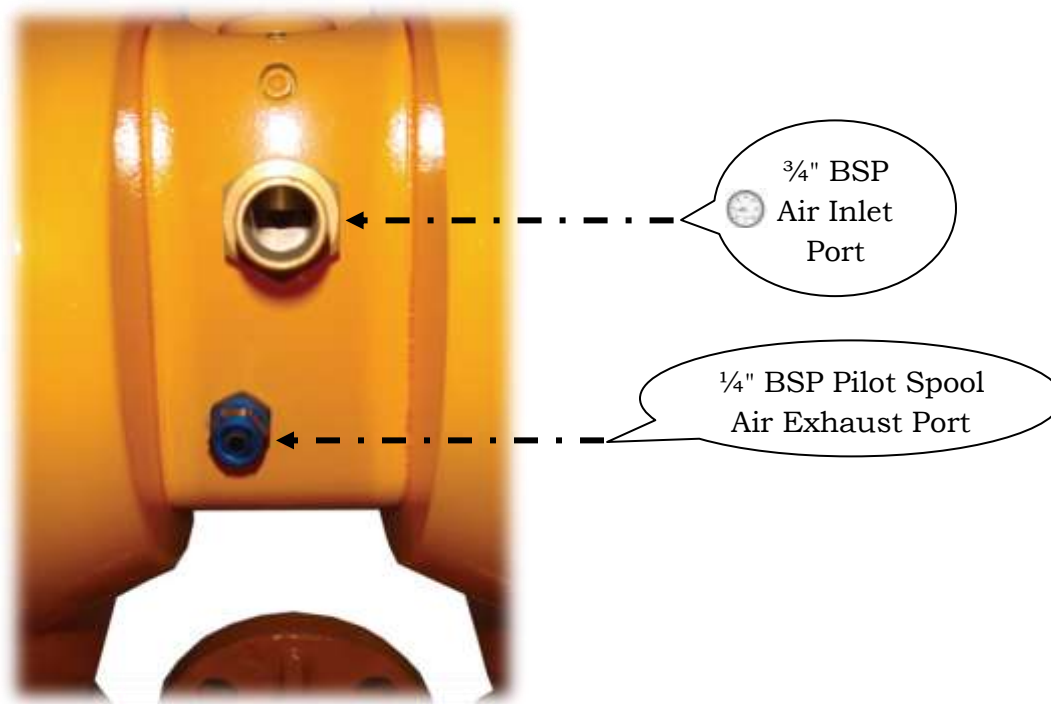

When the pumps are installed in the applications involving flooded suction or suction head pressures, a gate valve should be installed in the suction line to permit closing of the line for pump service.

If the pump is to be used in a self-priming application, be sure that all connections are alright and that the suction-lift is within the ability of the model.

Pumps in service with a positive suction head are most efficient when inlet pressure is limited to 0.5 to 0.7 bar (7-10 psig). Premature diaphragm failure may occur if positive suction is 0.7 Bar (10 psig) and higher.

The *Neoflux sf 50* will pass 12.7mm (½") compressible solids when Ball Check Valves are installed. Whenever the possibility exists that larger solid objects may be sucked into the pump, a strainer should be used on the suction line or change the Ball Check Valves to Flap Valves to increase Solid Passage.

**Caution:** *Neo-Sync* Pumps are not submersible.

## Viscous Fluid Application:

Viscosity **versus** Pump efficiency Chart

### AODD Pump Viscosity Chart

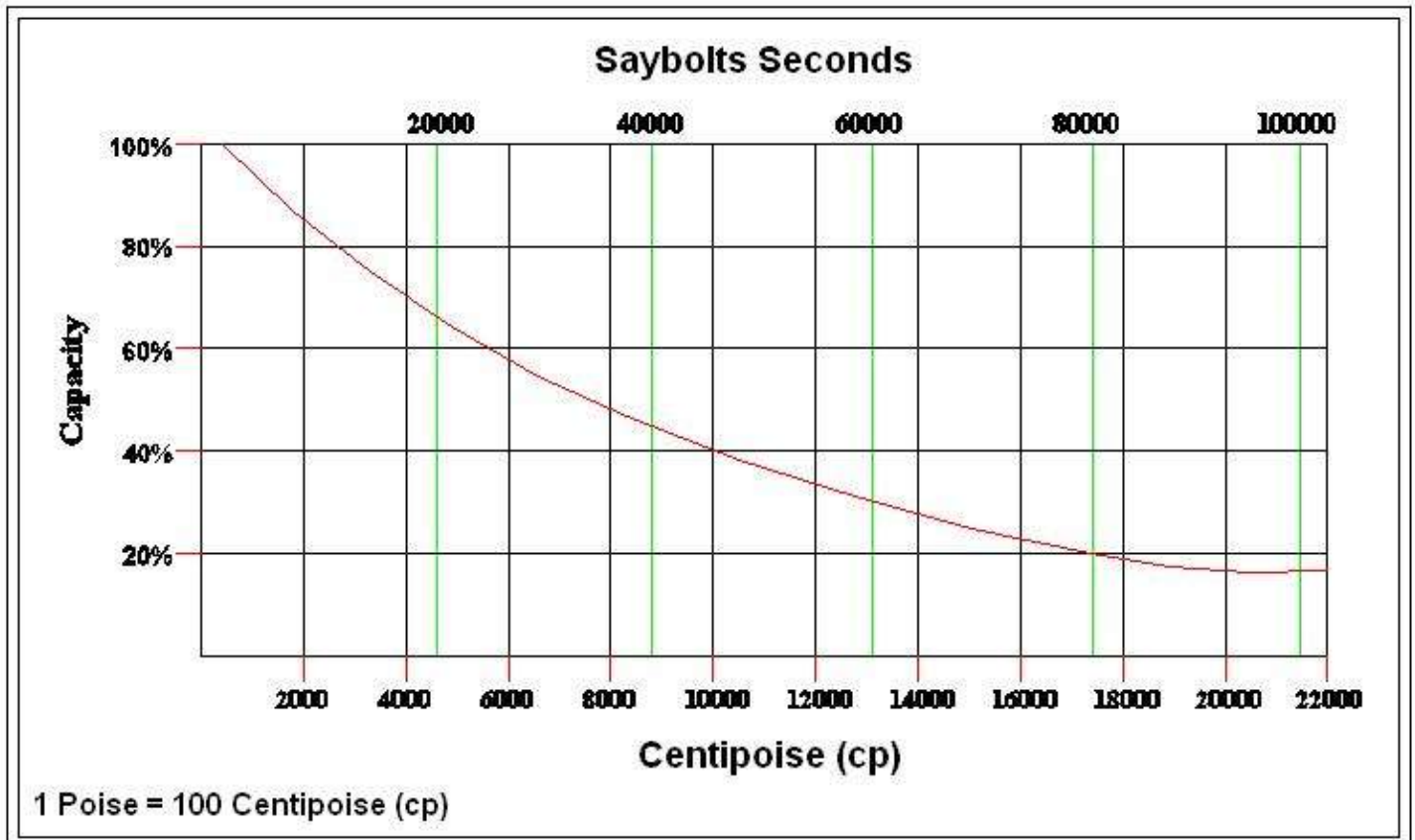

As you can see from the graph above, as viscosities of the fluid increases, the discharge capacity of the pump decreases.

#### Points to remember when pumping high viscous fluids:

1. Position the pump close to or below the level of the fluid source.
2. Suction lines should be increased in size – up to 3 times the size of the pump manifold inlet. Dual manifolds may be used when available.
3. Start the pump slowly using a control valve on the air line.
4. If greater capacity is required, select a larger pump.

## ***sf* 50 – 2" The Sanitary Pump**

---

### Suction & Discharge Piping:

Suction & Discharge Piping should be fully supported & anchored near to but independent of the pump. The piping to the pump should be a hose, to prevent undue stress & strain on the pump connections & piping.

#### **Connection of Suction Pipe / Hose:**

Remember that the suction pipe / connection is the most critical point, especially if the pump is priming. Just a small leakage will dramatically reduce suction capability of the pump. When connection the suction hose, following is recommended:

- For satisfactory operation, use reinforced hose (the suction power may otherwise shrink the hose) or other flexible piping. The internal diameter of the hose should be the same as on the suction connection (at the bottom of the pump) to have best suction capability.
- Make sure that the connection hose – pump is completely tight; otherwise the suction capability will be reduced.
- Always use a short suction pipe as possible. Avoid air pockets which can arise with long piping.

#### **Connection of Discharge Pipe / Hose:**

- For this connection it is only recommended a simple positive flow connection. Use a hose or a flexible piping (minimum one meter) between the discharge connection and any rigid fixed piping. Coil the hose at least one turn. All components (hose, pipe, valves etc.) on the discharge piping must be designed for minimum PN 10.

### Air Connection:

Screw the air hose into the air intake on the center section of the pump with for example a bayonet coupling. For best efficiency, use the same hose diameter as the internal diameter of the connection on the air intake.

### Air Treatment System:

The *Neo-Flo* Air Valve has self-lubricating technology & is designed for oil free air. Lubrication of the air is **NOT ALLOWED**. However, if the air is very dry (laboratory air), the air may be lubricated with water. Maximum air pressure is 8.6 bar. As prevention purpose, a filtration of air by means of a 5 $\mu$  filter or finer is recommended. Dirt in the air can under unfortunate circumstances be the cause of breakdown.

To facilitate the operation of the pump, we recommend an air treatment system connected to air supply. These components should be included:

1. 5 $\mu$  Air Filter & Regulator Combo (FR) to filter & adjust the air pressure
2. Manometer to read the actual pressure
3. Needle valve to adjust air flow

These components are included in *Neoflux* Air Treatment System which can be ordered from us.



1. Compressed Air Gate Valve
2. Air Filter & Pressure Regulator Combo
3. Compressed Air Flexible Hose
4. Compressed Air needle Valve
5. Suction Port Flexible Hose
6. Suction Port Gate Valve
7. Discharge Port gate Valve
8. Coiled Flexible Hose. (Un-Coiled will also work)
9. Discharge Flow Gauge

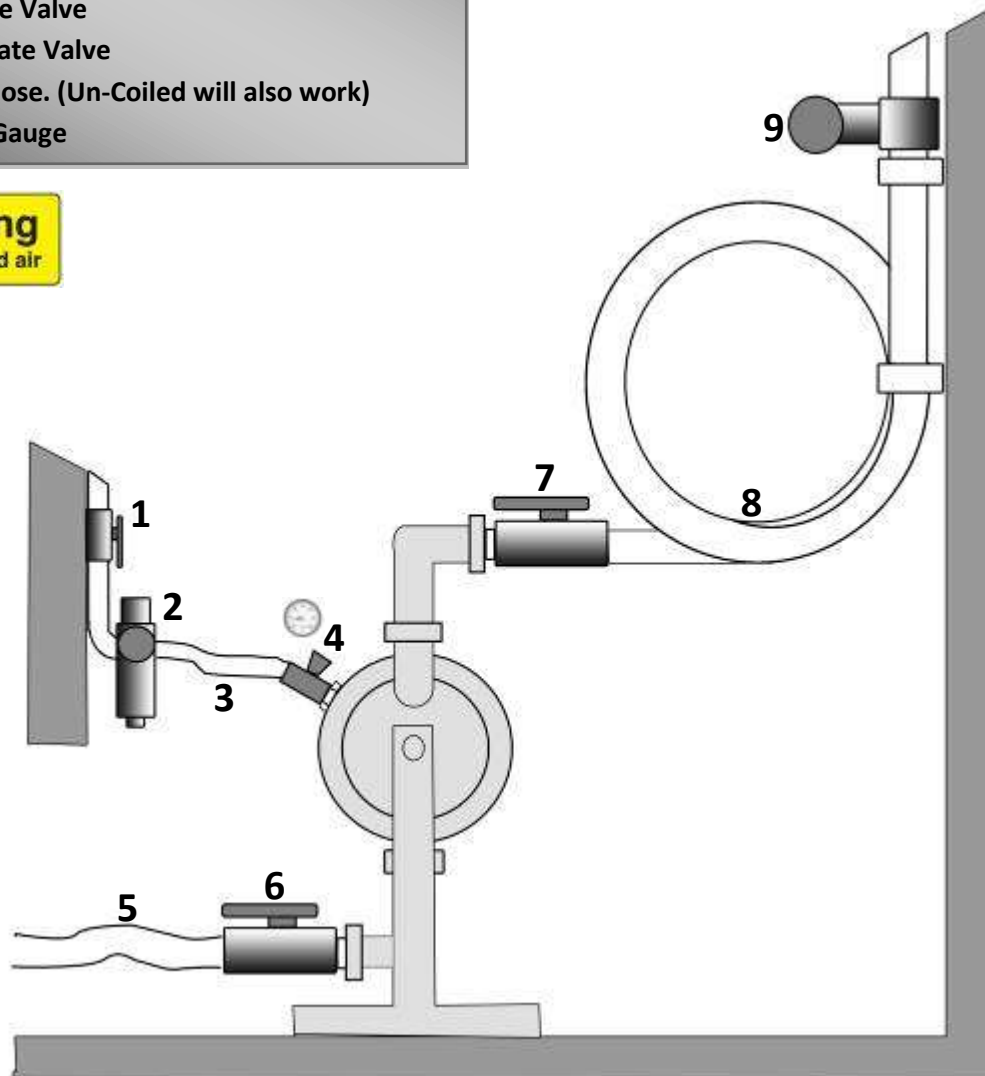

**AIR OPERATED PUMPS:**

To stop the pump from operating in an emergency situation, simply close the air shut off valve (user supplied) installed in the air supply line. A properly functioning valve will stop the air supply to the pump, therefore stopping output. This air shut off valve should be located far enough away from the pumping equipment such that it can be reached safely in an emergency situation.

**NOTE:**

In the event of a power failure, the air shut off valve should be closed, if restarting of the pump is not desirable once power is regained.



**CAUTION**

The Air Exhaust should be piped to an area for safe disposition of the product being pumped, in the event of a diaphragm failure.

## **sf 50 – 2" The Sanitary Pump**

### Pump Handling & Commissioning

Handle the pump from manifolds to move. *sf50* & *sf75* pumps must be handled by at least two persons. Hoist the pump using suitable equipment according to the weight shown on the plate.

The support of the pump is furnished with mounting holes. Fix the pump on a stable foundation, which is able to absorb vibrations. It is essential for the operation of the pump to mount the pump with the feet in a downward direction. (See Diagram on Page: 15)

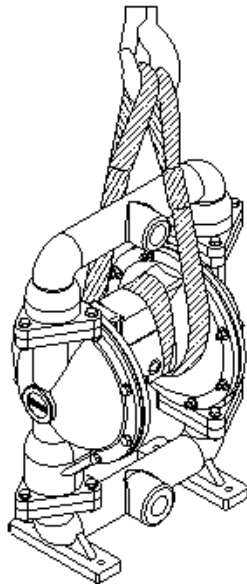

*Figure: Moving the pump with crane*

Install the pump to desired place in vertical position.

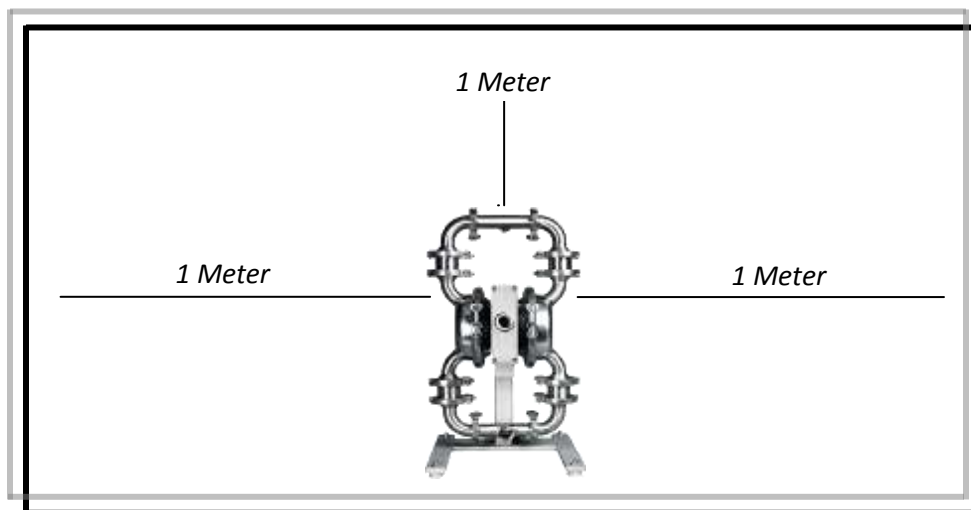

*Figure: Minimum space requirement around the diaphragm pump*

## sf 50 – 2" The Sanitary Pump

### **WARNING!!**



**Warning**  
Compressed air

If the pump works in fullest capacity continuously, the diaphragms & valves wear & tear will increase. To avoid that, pump must be chosen with one step higher capacity so that the performance of the pump falls under center of the curve.

### Suggested Operation & Maintenance

*Neoflux* AODD pumps are pre-lubricated & do not require in-line lubrication. If pump is heavily lubricated by an external source, the pump's internal lubrication may be washed away. If pump is then moved to non-lubricating location, it may need to be disassembled & re-lubricated. Pump discharge rate can be controlled by limiting the volume and/or pressure of the air supply to the pump (preferred method). An air regulator is used to regulate air pressure. A needle valve is used to regulate volume. Pump discharge rate can also be controlled by throttling the pump discharge by partially closing a valve in the discharge line of the pump. This action increases friction loss, which reduces flow rate. This is useful when the need exists to control the pump from a remote location. When the pump discharge pressure equals or exceeds the air supply pressure, the pump will stop; no bypass or pressure relief valve is needed, and pump damage will not occur. The pump has been "deadheaded". It can be restarted by reducing the fluid discharge pressure, or increasing the air inlet pressure. *Neoflux* pumps solely run on compressed air and does not generate heat, therefore your process fluid temperature will not be affected.



#### **Maintenance & Inspections:**



Since each application is unique, maintenance schedules may be different for every pump. Frequency of use, line pressure, viscosity & abrasiveness of process fluid all affect the parts life of *Neoflux* Pump. Periodic inspections have been found to offer the best means for preventing unscheduled pump downtime. Personnel familiar with the pump's construction and service should be informed of any abnormalities that are detected during operation.



#### **Hazards Generated By Noise:**



Pump noise can be excessive under certain operating conditions, e.g. High air pressure supply & little or no discharge head. Extended periods of operation under such conditions can create a hazard to operators working in proximity to the pumps. Ways to avoid this hazard are listed as follows:

- Use proper hearing protection devices.
- Use *Neo-Muff* Silencers on the pump's air exhaust. It will reduce the noise level to as low as 66dB.
- Plumb the pump's exhaust air to an area not in proximity of plant workers.
- Use elastomeric Valve Balls in lieu of PTFE Valve Balls since soft balls reduce noise. (Ensure proper chemical resistance of ball elastomers used)

## **sf 50 – 2" The Sanitary Pump**

---

### Troubleshooting FAQ's

#### ❖ **Pump will not run or run slowly.**

- ✓ Ensure that the air inlet pressure is at least 0.35 bar (5 psig) above startup pressure and that the differential pressure (the difference between air inlet and liquid discharge pressures) is not less than 0.7 bar (10 psig). 
- ✓ Check air inlet filter for debris.
- ✓ Check for extreme air leakage which would indicate worn seals/bores in the air valve, pilot spool, and main shaft. Also check for air leakage from End-Caps on Air Valve Assembly.
- ✓ Disassemble pump and check for obstructions in the air passageway or objects which would obstruct the movement of internal parts.
- ✓ Check for sticking ball check valves. If material being swelling may occur. Replace ball check valve and seals with proper elastomers. In addition, valve balls become smaller as the wear. This may cause them to become stuck in the seats. In this case, replace balls and seats.
- ✓ Check for broken inner piston, which will prevent the air valve spool from shifting.
- ✓ Remove plug from pilot spool exhaust, check pilot spool exhaust for blockage.

#### ❖ **Pump runs but little or no product flows.**

- ✓ Check for pump cavitations; slow pump speed down to allow thick material to flow into liquid chambers.
- ✓ For Suction lifts exceeding 15 feet, fill the suction pipe with liquid prior to priming.
- ✓ Verify that vacuum required to lift liquid is not greater than the vapor pressure of the material being pumped (Cavitation).
- ✓ Check for sticking ball check valves. If material being pumped is not compatible with pump elastomers, swelling may occur. Replace ball check valve and seals with proper elastomers. In addition, valve balls become smaller as the wear. This may occur them to become stuck in seats. In this case replace balls & seats.

#### ❖ **Pump Air Valve freezes.**

- ✓ Check for excessive moisture in compressed air. Install either a dryer, or hot air generator for compressed air. Alternatively, a coalescing filter may be used to remove the water from the compressed air in some application.

❖ **Air Bubble in pump discharge.**

- ✓ Check for ruptured diaphragm.
- ✓ Check tightness outer pistons.
- ✓ Check torque of clamp bolts and integrity of O-rings and seals, especially at intake manifold.
- ✓ Ensure pipe connections are air tight.

❖ **Product comes out of Air Exhaust.**

- ✓ Check for diaphragm rupture.
- ✓ Check tightness of outer piston to shaft.

# sf 50 – 2" The Sanitary Pump

## Disassembly / Reassembly Directions



**READ FIRST!**



Before any maintenance or repair is attempted, the compressed air line to the pump should be disconnected and all air pressure allowed to bleed from the pump. Disconnect all intake, discharge, and air lines. Drain the pump by turning it upside down and allowing any fluid to flow into a suitable container. Be aware of any hazardous effects of contact with your process fluid.

**NOTE:** The model photographed for these instructions incorporates rubber diaphragms, balls, and seats. Models with *PTFE* diaphragms, balls and seats are the same except where noted.



### Pump Disassembly Directions

**Tools Required:**



Adjustable Wrench

Vise equipped with soft jaws (such as plywood or plastic)



**Step 1:**

Please note alignment marks on liquid chambers. Use to properly align liquid chamber to center section



**Step 2:**

Loose the wing nut & remove both discharge manifolds Tri-Clamps.



**Step 3:**

Remove the discharge manifold & manifold gaskets.



**Step 6:**

Loosen the Wing Nut & remove the inlet manifold Tri-Clamps.



**Step 4:**

Next, remove the Tri-Clamps that secure the Ball Valve Housing to Liquid Chamber.



**Step 7:**

Next, remove the Tri-Clamps that secure Ball Valve Housing to the Liquid Chamber.



**Step 5:**

Next, remove the ball valve housing, valve ball & gasket.



**Step 8:**

Then, remove the Ball Valve Housing, Ball Valve & gasket from liquid chamber



**Step 9:**

Now, the large clamp bands can be removed.  
NOTE: Alignment marks should be placed on the liquid chamber & air chamber for ease of accurate reassembly.



**Step 11:**

Using two adjustable wrenches, turning in the opposite direction, loosen & remove one of the two outer piston.



**Step 10:**

Next, remove the liquid chamber from the center section assembly.



**Step 12:**

After loosening & removing the outer piston, the remaining diaphragm assembly & shaft can be removed from the center section assembly.



## Neo-Tune Air Valve / Center Section Disassembly Directions

**Tools Required:**

M6 Size Allen Key  
Cerclip Pliers  
O-ring Pick



**Step 1:**

Using a M6 size Allen Key, loosen the Air Valve bolts.



**Step 3:**

Lift away air valve assembly and remove air valve gasket for inspection. Replace if necessary.



**Step 2:**

Remove muffler plate and air valve bolts from air valve assembly exposing muffler gasket for inspection. Replace if necessary.



**Step 4:**

Remove air valve end cap to expose air valve spool by simply lifting up on end cap once air valve bolts are removed. *Note:* Neoflux sf 50 Model's air valve incorporates an end cap at both ends of the air valve.

**Step 5:**

Remove the air valve spool from the air valve body by threading one air valve bolt into the end of the air valve spool and gently sliding the spool out of the air valve body. Inspect seals for signs of wear and replace entire assembly if necessary. Use caution when handling air valve spool to prevent damaging seals. *Note:* Seals should not be removed from assembly. Seals are not sold separately.

**Step 6:**

Remove pilot sleeve retaining snap ring on both sides of center section with snap ring pliers.

**Step 7:**

Remove pilot spool sleeve from center section.

**Step 8:**

Using an o-ring pick, gently remove the o-ring from the opposite side of the “notched end” on one side of the pilot spool. Gently remove the pilot spool from pilot spool sleeve and inspect for nick, gouges and wear. Replace pilot sleeve or outer sleeve o-rings if necessary. During re-assembly, never insert the pilot spool into the sleeve with the “notched end” first, this end incorporates the urethane o-ring and will be damaged as it slides over the ports cut in the sleeve. *Note:* Seals should not be removed from pilot spool. Seals are not sold separately.

**Step 9:**

Check center section shaft seals for signs of wear. If necessary, remove the shaft seals with o-ring pick and replace.

## Grounding Strap for Flammable Fluid Transfer

Flammable Fluid Transfer pumps must be electrically grounded using the grounding strap provided. Improper grounding can cause improper and dangerous operation. To properly attach the grounding strap to *sf 50* pump, first position the grounding strap eyelet over the one longer manifold bolt on the inlet manifold. Then secure it using nut included. This is done to avoid loosening any of the wetted path components and possibly creating a leak. Grounding the pump must be done in accordance with local codes, or in the absence of local codes, an industry or nationally recognized code having jurisdiction over the specified installation.



Grounding Symbol

## Re-assembly Directions

### **GENERAL RE-ASSEMBLY TIPS:**

Upon performing applicable maintenance to the air distribution system, the pump can now be reassembled. The air distribution system needs to be assembled first, then the diaphragms and finally the wetted path. The following tips will assist in the assembly process.

- ❖ Lubricate air valve bore, center section shaft and pilot spool bore with grease that has no water washout capability & excellent oscillation property.
- ❖ Clean the inside of the center section shaft bore to ensure no damage is done to new shaft seals.
- ❖ A small amount bearing grease can be applied to the muffler and air valve gaskets to locate gaskets during assembly.
- ❖ Make sure that the exhaust port on the muffler plate is centered between the two exhaust ports on the center section.
- ❖ Stainless bolts should be lubed to reduce the possibility of seizing during tightening.
- ❖ Use a hammer to tamp lightly on the large clamp bands to seat the diaphragm before tightening.

### **AIR VALVE BODY INSTALLATION:**

Note: Air Valve Piston Seals should not be removed. Seals are not sold separately.

- ❖ Slowly insert the air valve piston into the lubricated air valve bore with a rotating motion to avoid the damage of piston seal.
- ❖ Insert air valve end-cap on bottom of the Air valve body.
- ❖ Install air valve gasket and muffler plate gasket.
- ❖ Attach the Muffler plate with the muffler plate gasket in correct direction.
- ❖ Using hex head wrench, tighten the air assembly with the center section.

### **PILOT SPOOL INSTALLATION:**

Note: Pilot Spool Seals should not be removed. Seals are not sold separately.

- ❖ Lubricate pilot spool bore as well as pilot spool sleeve with bearing grease that has no water washout capability & excellent oscillation property to avoid damage to pilot spool O-Rings while sliding in.
- ❖ Using an O-ring pick, gently remove the O-ring from the opposite side of the “notched end” on one side of the pilot spool for insertion. During re-assembly of pilot spool, never insert the pilot spool into the sleeve with the “notched end” first, this end incorporates the urethane o-ring and will be damaged as it slides over the ports cut in the sleeve.
- ❖ Gently insert pilot spool Assembly into center section Pilot Sleeve Bore.
- ❖ Insert the Cerclip into the grooves on both ends of center section with internal / external Cerclip pliers.

### **SHAFT SEAL INSTALLATION:**

#### **PRE-INSTALLATION**

- ❖ Once all of the old seals have been removed, the inside of the bushing should be cleaned to ensure no debris is left that may cause premature damage to the new seals.

#### **INSTALLATION**

The following tools can be used to aid in the installation of the new seals:



- Needle Nose Pliers
  - Phillips Screwdriver
  - Electrical Tape
- ❖ Wrap electrical tape around each leg of the needle nose pliers (heat shrink tubing may also be used). This is done to prevent damaging the inside surface of the new seal.
  - ❖ With a new seal in hand, place the two legs of the needle nose pliers inside the seal ring.
  - ❖ Open the pliers as wide as the seal diameter will allow, then with two fingers pull down on the top portion of the seal to form kidney bean shape.
  - ❖ Lightly clamp the pliers together to hold the seal into the kidney shape. Be sure to pull the seal into as tight of a kidney shape as possible, this will allow the seal to travel down the bushing bore easier.
  - ❖ With the seal clamped in the pliers, insert the seal into the bushing bore and position the bottom of the seal into the correct groove. Once the bottom of the seal is seated in the groove, release the clamp pressure on the pliers. This will allow the seal to partially snap back to its original shape.
  - ❖ After the pliers are removed, you will notice a slight bump in the seal shape. Before the seal can be properly resized, the bump in the seal should be removed as much as possible. This can be done with either the Phillips screwdriver or your finger. With either the side of the screwdriver or your finger, apply light pressure to the peak of the bump. This pressure will cause the bump to be almost completely eliminated.
  - ❖ Lubricate the edge of the shaft with Grade 2 EP bearing grease.
  - ❖ Slowly insert the center shaft with a rotating motion. This will complete the resizing of the seal.
  - ❖ Perform these steps for the remaining seal.

## **sf 50 – 2" The Sanitary Pump**

---

### Rotating The Pump With Swivel Pump Stand

For ease of maintenance & cleaning, *Saniflux* pump offers an optional Swivel Pump Stand. This stand allows the pump to be drained by rotating the pump so that the fluid can flow out of discharge & into a suitable container.

#### **Draining Pump Contents:**

To drain the pump of its contents, first dis-connect the *Tri-Clamp* Inlet & Discharge connections. Next loosen the anti-rotation bolt (Item-A); by turning counter-clockwise. Do not Remove the bolt; only loosen the bolt two turns. After loosening the anti-rotation bolt, rotate the pump 180°. This will allow the fluid within the pump to flow out of the discharge & into a suitable container. After draining the pump, rotate the pump back to the upright position & tighten the anti-rotation bolt.

#### **Dis-assembling the Pump from Swivel Pump Stand:**

*Saniflux* series pumps are very heavy. It is recommended that the pump be disassembled while attached to the stand. If it is necessary to remove the pump from the stand while fully assembled, use a hoist or mechanical means to support the pump as it is removed from the stand.

To remove your *Saniflux* series pump from the swivel pump stand, first loosen the anti-rotation bolt (Item-A) by turning counter-clockwise. Next, ensure the entire pump weight is supported by hoist and loosen the locking pin (Item-B) by turning counter-clockwise. This will allow the pump to be removed from the stand.



**CAUTION:** Removal of the locking pin (Item-B) will allow the pump to fall from the stand, potentially causing injury to the operator or personnel in the immediate area. Never operate or store the pump without the locking pin (item-B) in place and properly torqued.

**Note:** The center block-to-bushing bolts (item-D) attach the center block mounting bushing (Item-C) to the center block. These bolts do not need to be removed to remove the pump from the stand.

## **sf 50** – 2" The Sanitary Pump

---

### Pump Cleaning (CIP)

The design of the **Saniflux** Hygiene pump allows for ease of cleaning. The **sf 50** pump can be cleaned in place without disassembly. Before any cleaning is attempted, ensure that the cleaning fluids are compatible with all wetted components.

**The following are some details to consider when cleaning the sf 50 pump.**

- Through the certification process, the **sf 50** pump has been validated to clean equivalent to the inlet tubing of the same diameter. The cleaning chemical supplier should be consulted and advised of this for their chemical solution and application. The same guideline for duration of cleaning cycle and temperature of cleaning fluid apply.
- Suggested flow rate for the **sf 50** pump is 50 gpm / 11 m<sup>3</sup>/hr (usually higher is better).
- Typical CIP temperature is 77 °C to 82 °C (170 °F to 180 °F).
- Typical chemicals include NaOH (sodium hydroxide) caustic for wash and light acid and sanitizers for rinse.
- Once an initial CIP regimen is established, it may need to be modified to accommodate specific process and product differences or requirements. The most common adjustments include:
  - Changing cleaning time (extended or reduced pre-rinse, wash, rinses).
  - Changing cleaning flow rate.
- The cleaning variables are related so that a pump user may be able to reduce the cleaning time by increasing the flow rate or chemical mix.
- **Chlorinated sanitizers are known to cause premature failure of stainless steel and should be avoided.**

#### **To Clean Pump:**

- Activate the CIP system while slowly cycling the pump.

**NOTE:** A typical CIP temperature limit is 90 °C (195 °F). If the CIP temperature is greater than 90 °C (195 °F), damage to the pump may occur.

#### **To Drain Pump:**

After the CIP procedure, the pump usually has to be drained from the CIP fluid. The **Saniflux** series is supplied with a hygienic stand, enabling 360° rotation of the pump unit.

1. Dis-connect the pump from the piping.
2. Simply loose the two socket head cap screws & rotate the pump at 180° (see Figure A) & let the remaining fluid drain off. The air connection may be left connected during this rotation.
3. Rotate back to the normal position, connect the pump with the correct pipes & fix the socket head cap screws.

## sf 50 – 2" The Sanitary Pump

### Pump Storage

If the equipment is to be stored prior to installation, place it in a clean location. Do not remove the protective covers from the suction, discharge & air connections which have been fastened to keep pump internals free of debris. Clean the pump thoroughly before installation.

#### Storage after use:

- If you are not going to use the pump for a long time, clean it before storage.
- Discharge the Pump completely.
- Flush it with water or cleaning agent.
- Disconnect all hoses.

### Pump Spare Parts Storage

Neoflux recommends buyers to keep below spares in stock to make pump run efficiently. Since the extent of recommend spare parts storage depends on the period of pump usage & its different operating conditions, you should consult us or our authorized distributor.

If recommended procedures are followed (*Refer to page: 32 for storage recommendations*) and there are no extremes, the expected shelf-life is as follows:

**Neo-Flex**  
DIAPHRAGM TECHNOLOGY

**Neo-Tef**  
DIAPHRAGM TECHNOLOGY

Recommended Spares List		
Part Description	Expected Shelf Life*	Quantity.
Neo-Flex Rubber Diaphragms	3 – 4 Years	1 Set – 2 Pcs.
Neo-Tef PTFE Diaphragms	Indefinite	0 Set
Rubber Valve Balls	2 - 3 Years	1 Set – 4 Pcs.
PTFE Valve Balls	Indefinite	0 Set
Rubber Valve Seats	3 - 4 Years	1 Set – 4 Pcs.
Glyd Rings & Bushings	Indefinite	1 Set – 2 Pcs.
Air Distribution System	N/A	1 Set
Gaskets & Tri-Clamp O-rings	2 - 3 Years	1-Set
Pilot Spool Assembly	Indefinite	1-Set
Outer Pistons	Indefinite	1-Set



\* The shelf life of any rubber article such as a diaphragm is dependent upon many factors relating to the storage conditions. If recommended procedures are followed and there are no extremes, the expected shelf life can be obtained:

#### **Liability when using non-genuine spare parts:**

The installation and/or use of non-genuine spare parts or accessories can have a negative effect on design features of the air operated diaphragm pump and thus adversely affect its operation. For damage caused by the use of non genuine spare parts and accessories on pump, system or product all liability and warranty is excluded.

## **sf 50 – 2" The Sanitary Pump**

---

### Diaphragms & Other Elastomers Storage Recommendations

The physical properties and the performance of rubber diaphragms & articles can deteriorate during long periods of storage. This can lead to the rubber component becoming unsuitable for service due to excessive hardening, softening, cracking, crazing or other surface degradation. These changes may be the result of one factor or a combination of factors. For example, the effects of oxygen, ozone, light, heat and humidity.

#### *Recommendations:*

##### **Temperature:**

In order to avoid certain forms of deterioration that may occur at higher temperatures, storage temperatures of diaphragms should be below 77°F (25°C). The effects of low temperatures are not permanently damaging, but articles may stiffen more than usual. Thus, care should be taken to avoid distortion.

##### **Humidity:**

Store Diaphragms, Valve Balls, Valve Seats & O-rings in a dry environment to avoid condensation.

##### **Light:**

Vulcanized / bonded / meshed Diaphragms & Valve Balls should be protected from light, especially direct sunlight and strong artificial light with a high ultraviolet content. Unless the diaphragms are packed in opaque containers, it is advisable to cover windows of storage rooms with an orange screen.

##### **Oxygen & Ozone:**

Whenever possible, diaphragms should be protected from circulating air by wrapping or storing in airtight containers. Ozone is very abrasive toward rubber. Consequently, storage rooms should not contain any equipment capable of generating ozone such as mercury lamps, electric motors and any other equipment that produces electrical sparks or discharge.

##### **Deformation:**

Whenever possible, diaphragms should be stored in a relaxed condition free from tension, compression or other deformation.

##### **Contact with Liquid or Semi-Solid Materials:**

Rubber Parts should not come in contact with liquids or semisolid materials, especially solvents, oils and greases at any time during storage.

##### **Contact with Metals:**

Certain metals, especially copper, manganese and iron, are known to have a damaging effect on rubber. Protection should be given by wrapping or separating with paper or polythene or using Spares Packed diaphragms.

##### **Rotation of Stocks:**

Vulcanized or cured rubber should remain in stores for as short of a period as possible (Refer to Shelf Life table on page: 27). Therefore, articles should be issued from stores in strict rotation with a date *First-in / First-Out Method*.

##### **Cleaning:**

Care must be taken in cleaning vulcanized rubber. Wash with mild soap and water, and avoid using organic solvents such as trichloroethylene, carbon tetrachloride, or petroleum.



# sf 50 – 2" The Sanitary Pump

## Exploded View

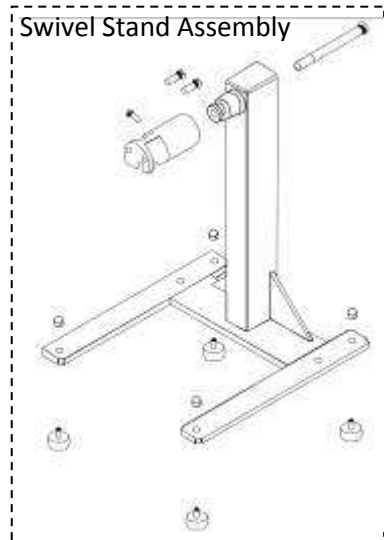
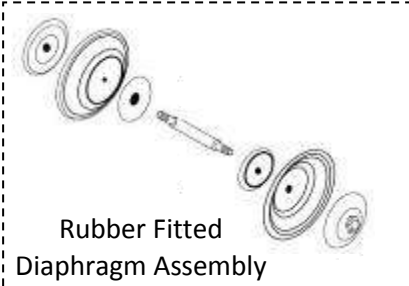
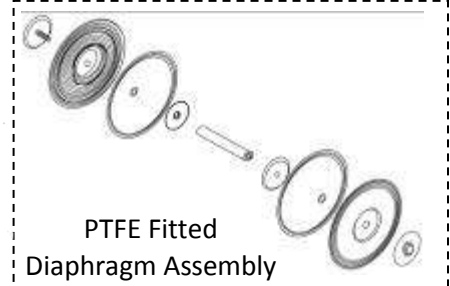
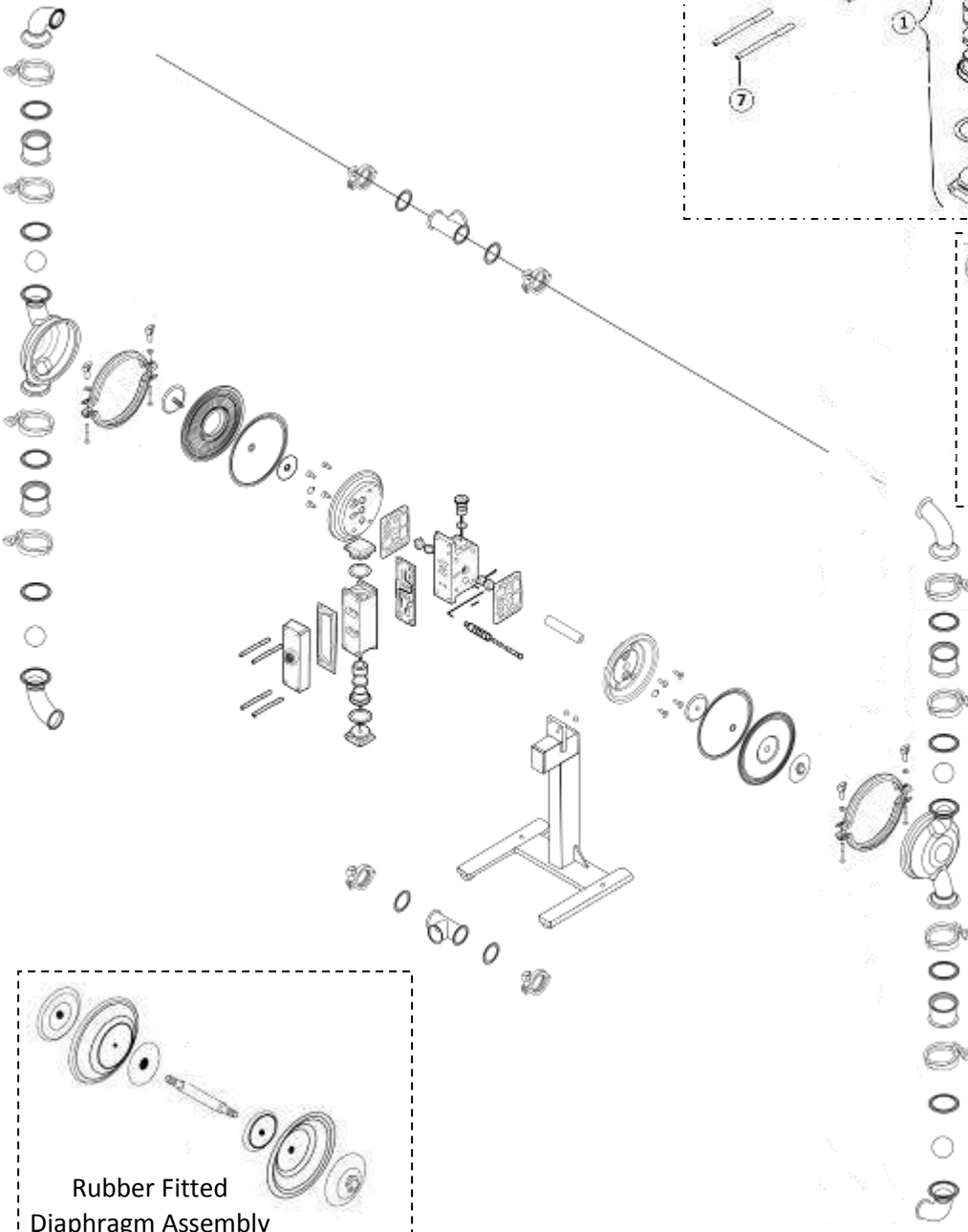
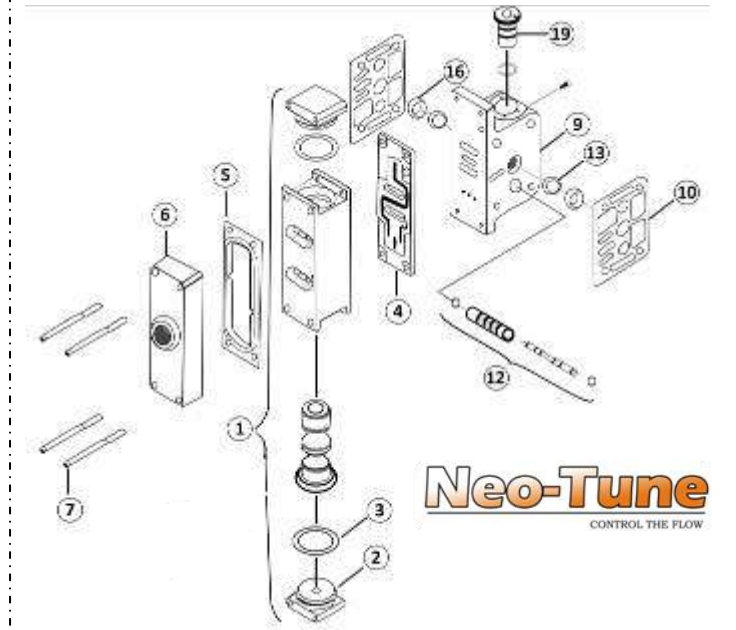

# sf 50 – 2" The Sanitary Pump

## Parts Listing

No.	Description	Qty.	sf 50 P/N
<b>1</b>	<b>Neo-Tune Air Valve Assembly</b>	<b>1</b>	<b>50-0005-000</b>
2	End Cap	2	50-0005-001
3	End Cap O-ring	1	50-0007-009
<b>4</b>	<b>Air Valve Gasket</b>	<b>1</b>	<b>50-0007-011</b>
<b>5</b>	<b>Muffler Plate Gasket</b>	<b>1</b>	<b>50-0007-012</b>
6	Muffler Plate	1	50-0005-004
7	Fastener – Air Assembly	4	50-0009-004
8	Sanitary Neo-Muff Silencer	1	50-0005-005
9	Center Section	1	50-0004-001
<b>10</b>	<b>Center Section Gasket</b>	<b>2</b>	<b>50-0007-013</b>
11	Air-Inlet Bushing	1	
<b>12</b>	<b>Pilot Spool Assembly</b>	<b>1</b>	<b>50-0004-002</b>
<b>13</b>	<b>Guide Ring</b>	<b>2</b>	<b>50-0007-001</b>
14	Retaining Ring (Cerclip)	2	50-0004-003
15 (a)	Neo-Tune Shaft (Rubber Fitted)	1	50-0004-004-1
15 (b)	Neo-Tune Shaft (PTFE Fitted)	1	50-0004-004
<b>16</b>	<b>Shaft Bushing</b>	<b>2</b>	<b>50-0007-018</b>
17 (a)	Inner Piston (Rubber Fitted)	2	50-0004-005
17 (b)	Inner Piston (PTFE Fitted)	2	
18 (a)	Outer Piston (Rubber Fitted)	2	50-0004-006
18 (b)	Outer Piston (PTFE Fitted)	2	
19	Air Adjustment Knob	1	50-0004-007
20	Elbow – Tri-Clamp Design	4	50-0001-001
21	T-Section – Tri-Clamp Design	2	50-0001-002
22	Liquid Chamber - Clamp Design	2	50-0002-001
23	Air Chamber – Clamp Design	2	50-0003-001
24	Ball Cage	4	50-0001-003
<b>25</b>	<b>Valve Ball</b>	<b>4</b>	<b>Refer to elastomeric chart</b>
26	Tri-Clamp - Manifold	4	50-0009-001
<b>27</b>	<b>Tri-Clamp Gasket - Manifold</b>	<b>4</b>	<b>Refer to elastomeric chart</b>
28	Tri-Clamp – Ball Cage	8	50-0009-002
<b>29</b>	<b>Tri-Clamp Gasket – Ball Cage</b>	<b>8</b>	<b>Refer to elastomeric chart</b>
30	Chamber Clamp	2	50-009-003
<b>31</b>	<b>Diaphragm</b>	<b>2</b>	<b>Refer to elastomeric chart</b>

All Boldface Items are primary wear parts.

### MOC Options

#### Wetted Parts

SS-304 / SS-316 / SS-316L

#### Non-Wetted Parts

Aluminum / Nickel Plated Aluminum / SS-304 / SS-316 / SS-316L

## sf 50 – 2" The Sanitary Pump

### sf 50 Elastomeric Options

Material	Diaphragm P/N	Valve Ball P/N	Tri-Clamp Gasket Manifold P/N	Ti-Clamp Gasket Ball Cage P/N
Neoprene	50-0008-001	50-0006-001	50-0007-TC1	50-0007-TC2
Viton	50-0008-002	50-0006-002	50-0007-TC1	50-0007-TC2
Buna-N	50-0008-003	50-0006-003	N/A	N/A
PTFE	50-0008-005	50-0006-004	50-0007-TC1	50-0007-TC2

**NOTE:** Not all materials are available for all models. Please contact *Neoflux* for material options for your pump.

### Elastomers Temperature Limitations

Material	° Centigrade	° Fahrenheit
Neoprene	-18°C to 93°C	0°F to 200°F
Viton®	-38°C to 165°C	-40°F to 340°F
Buna-N®	-12°C to 80°C	10°F to 178°F
Polyurethane	-11°C to 60°C	10°F to 144°F
PTFE®	4°C to 105°C	39°F to 219°F
Polypropylene	Max. 75°C	Max. 167°F



**CAUTION:** Maximum temperature limits are based upon mechanical stress only. Certain chemicals will significantly reduce maximum safe operating temperatures. Consult *Neoflux* Chemical Resistance Guide for chemical compatibility and temperature limits or contact us for more details.

Viton® & Teflon® are registered trademark DuPont Dow Elastomers.

## sf 50 – 2" The Sanitary Pump

---



### WARRANTY

Each and every product manufactured by *Neoflux* is built to meet the highest standards of quality. Every pump is functionally tested to insure integrity of operation.

*Neoflux* warrants that pumps, accessories and parts manufactured or supplied by it to be free from defects in material and workmanship for a period of 12 months (1) years from date of installation or 18 months (1.5) years from date of purchase, whichever comes first. Failure due to normal wear, misapplication, or abuse is, of course, excluded from this warranty.

Since the use of *Neoflux* pumps and parts is beyond our control, we cannot guarantee the suitability of any pump or part for a particular application and *Neoflux* shall not be liable for any consequential damage or expense arising from the use or misuse of its products on any application. Responsibility is limited solely to replacement or repair of defective *Neoflux* pumps and parts.

All decisions as to the cause of failure are the sole determination of *Neoflux*.

Prior approval must be obtained from *Neoflux* for return of any items for warranty consideration and must be accompanied by the appropriate MSDS for the product(s) involved. A Return Goods Tag, must be included with the items which must be shipped freight prepaid.

The foregoing warranty is exclusive and in lieu of all other warranties expressed or implied (whether written or oral) including all implied warranties of merchantability and fitness for any particular purpose. No distributor or other person is authorized to assume any liability or obligation for *Neoflux* other than expressly provided herein.

## Neoflux Signature Design Platform

---

ESADS + PLUS (External Serviceable Lube-Free Air Distribution System)

Complete In-Line Serviceable

*ON – OFF – ON.... RELIABILITY – GURANTEED!*

### DIAPHRAGM SHAFT GURANTEE

Durable Corrosion Resistance SS-304 & SS-410 Hard Chrome Grinded Diaphragm Shaft for smooth performance.

#### **GURANTEED!**

*not to yield under....*

- Tension
- Compression
- Bending
- Pump Operation



# Neo-Flo

AIR DISTRIBUTION SYSTEM

ONLY 3 MOVING PARTS MEANS FEWER REPLACEMENTS

*The Unbalanced & Non-stalling Air Valve Spool*

*The Pilot Spool*

*The Main Shaft*

Advanced Air Valve Spool eliminates the problem of freezing during the cycle and conduct a lube-free operation

Superb flow rate

Inspection of all *sf* series Air Distribution System can be done without removing the pump from service

This means Minimum Breakdown & Maximum Reliability

Unique to its design is On/Off reliability

Options of All metal as well as Plastic Air Distribution System & Center Block

Entirely Submersible

Silent Operation. With *Neo-Muff* Silencer, noise reduction is as low as 75 db

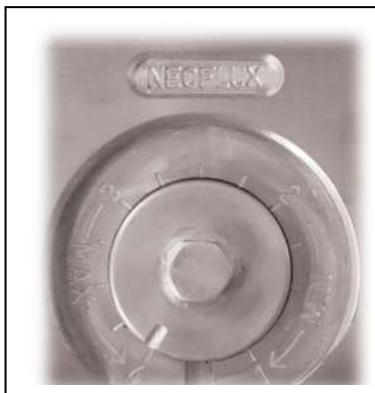

## Neo-Tune

CONTROL THE FLOW

This design incorporates Air-Regulator for discharge efficiency. It really contrives the flow you want

High performance with lower operational cost

Operational flexibility & higher flow rate

Simple & easy to control the flow rate

Entirely Submersible

## Neo-Sync

AUTOMATE THE FLOW

No changes to the pump's working principle

Electric as well as Pneumatic signals options available to control pump speed

Specifically for System Automation (PLC) with direct electrical interface

Superior displacement reliability means better accuracy

Efficient for batching & metering application

Externally controlled

Superior On / off reliability

Simple installation & easy monitoring

Explosion proof option also available

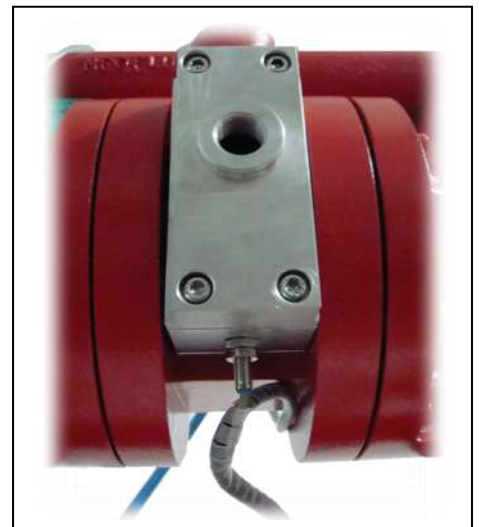

## Points to consider when selecting AODD Pump

---

To get the pump best suited to your industry application, please go through the below two steps in details.

### **Step: 1 – Check Temperature Limitations**

- What is the Material Pumping Temperature?

When choosing the AODD Pump Material, be sure to check the temperature limits for all wetted components. Elastomers may change Temperature limits.

*Example:* Viton® has a maximum limit of 176.7°C (350°F) but Polypropylene has maximum limit of only 79.4°C (175°F).

Maximum temperature limits are based upon mechanical stress only. Certain chemicals will significantly reduce maximum safe operating temperature. Consult us for chemical compatibility issues.

### **Step: 2 – Check Chemical Properties**

The first consideration when applying a Diaphragm pump to any application is to try and determine how abrasive and corrosive the product to be pumped is.

- What is the Pump Application? – Submersible / Transfer / Other
- Operating Method – Continuous / Intermittent
- What is the Chemical Viscosity?
- Is it Flammable?
- Is it Corrosive or Abrasive?

Corrosive liquids, by nature, directly attack the pump materials. The strength of a corrosive liquid depends on its concentration and temperature.

An Abrasive liquid is one that has particles in it. Some, like inks, have very fine particles, while others, like some paints, contain much larger particles. Handling abrasive liquids is a difficult application for any pump, because the abrasive particles promote pump wear.



Typical abrasive applications include:

- Paints and Coatings
- Inks
- Filled Roofing Asphalt
- Waste Oils
- Magnetic Oxide Tape Coatings
- Titanium Dioxide Slurries

- Is it Shear Sensitive?
- Is Material having Solid Particles? If Yes, What is the size of Particles?

# Pump Wetted Material Compatibility Chart

Wetted Section MOC	Numeric pH Level	Fluid Solutions
<i>Stainless Steel</i> <i>Polypropylene / PVDF</i>	14 13 12 11	Alkaline Caustic
<i>Cast Iron</i>	10 9	Basic
<i>Aluminum</i>	8 7 6	Neutral
<i>Polypropylene / PVDF</i> <i>Stainless Steel</i>	5 4 3 2 1 0	Acid

 Increasingly Alkalinity  
 Increasingly Acidity

pH is a measure of hydrogen-ion concentration. pH of 7 is neutral.

Below 7, *Acid*

Above 7, *Alkaline*

Litmus indicator **solution** turns **red** in acidic solutions and **blue** in alkaline solutions - and it turns **purple** in neutral solutions.

- ❖ The closer to pH 0 you go, the more strongly acidic a solution is.
- ❖ The closer to pH 14 you go, the more strongly alkaline a solution is.



## General Diaphragm Selection Guide

---

**CAUTION:** Temperature limits are based upon mechanical stress only. Certain chemicals will significantly reduce maximum safe operating temperatures. Consult engineering guides for chemical compatibility and temperature limits. It must be emphasized that none of these figures are absolute and are only general guidelines.

These guides for best diaphragm selection do not hold for the valve ball material. Because the diaphragms are securely gripped by their inner and outer beads, they can stand up to 20% swell without affecting pump performance. If the valve balls swell even a very small amount, they cannot function properly. Therefore, there will be cases where neoprene diaphragms will be the best selection but PTFE, Buna-N, EPDM or polyurethane balls will be required.

---

**Compound:** Neoprene

**Color:** Black

**Temperature Limits:**  $-18^{\circ}\text{C}$  to  $93^{\circ}\text{C}$  ( $0^{\circ}\text{F}$  to  $+200^{\circ}\text{F}$ )

**Estimated Life:** 10 Million Cycles

**Suitable Applications:**

An excellent general purpose diaphragm for use in non-aggressive applications such as Water-based Slurries, Well Water or Sea Water. Exhibits excellent flex life and low cost.

---

**Compound:** Buna-N

**Color:** Black with Red Dot

**Temperature Limits:**  $-12^{\circ}\text{C}$  to  $82^{\circ}\text{C}$  ( $+10^{\circ}\text{F}$  to  $+180^{\circ}\text{F}$ )

**Estimated Life:** 10 Million Cycles

**Suitable Applications:**

Excellent for applications involving petroleum/oil based fluids such as Leaded Gasoline, Fuel Oils, Non-Synthetic Hydraulic Oils, Kerosene, Turpentine's and Motor Oils.

---

**Compound:** Polyurethane

**Color:** Clear

**Temperature Limits:**  $-12^{\circ}\text{C}$  to  $66^{\circ}\text{C}$  ( $0^{\circ}\text{F}$  to  $+150^{\circ}\text{F}$ )

**Suitable Applications:**

An excellent general purpose diaphragm for use in Non-Aggressive applications. This material exhibits exceptional flex life and durability. *Neoflux's* least expensive diaphragm.

---

**Compound:** PTFE

**Color:** White

**Temperature Limits:**  $-4^{\circ}\text{C}$  to  $104^{\circ}\text{C}$  ( $+40^{\circ}\text{F}$  to  $+220^{\circ}\text{F}$ )

Also, when using a *PTFE* diaphragm, flow rates will be reduced by up to 25%. This is due to the inability of *PTFE* to flex as far as a rubber diaphragm which will decrease displacement per stroke.

**Suitable Applications:**

Excellent choice when pumping Highly Aggressive fluids such as Aromatic or Chlorinated Hydrocarbons, Acids, Caustics, Ketones and Acetates. Exhibits good flex life compared to a standard rubber diaphragm.

---



# Declaration of Conformity

The Neoflux product listed conforms to the standards & directives describe below.

Neoflux Representative (Responsible Person): *ATIT SHAH* Position: *V.P. of Engineering*

**Manufactured By:** *Neoflux Technic Private Limited*

Fabrique Par: 43 GIDC Industrial Estate,  
Fabricada Por: Phase – I,  
Hergestellt Von: Vatva,  
Fabbricato Da: AHMEDABAD – 382445,  
Fabrikant: GUJARAT,  
Valmistaja: INDIA  
Produsent: Tel.: +91 – 79 – 25830602  
Fabricante: : +91 – 79 – 25831185  
: +91 – 79 – 25835298  
Email – info@neoflux.in



**Pump Model Number:**

**Pump Serial Number:**

Modele, Type:  
Modelo, Typo:  
Modell, Type:  
Modello Tipo:  
Malli, Tyypit:

<b>Description:</b>	Air Distribution System – Diaphragm MOC – NRV MOC – Pump Housing MOC– Temperature Limitations – Special Remarks –
---------------------	--

**Authorized / Approved By:**

Approuve par:  
Aprobado por:  
Genehmigt von:  
Approvato da:  
Goedgekeurd door:  
Autorizado Por:

\_\_\_\_\_  
*ATIT SHAH,*  
*V.P. of Engineering*

**Date:**

Fecha:  
Datum:  
Data:  
Dato:

## Corporate Address

43 GIDC Industrial Estate,

Phase – 1, Vatva,

Ahmedabad – 382445,

Gujarat,

INDIA

email – [info@neoflux.in](mailto:info@neoflux.in)

[www.neoflux.in](http://www.neoflux.in)

### Contacts:

Atit Shah +91-9825009234/ [atitshah@neoplastindia.com](mailto:atitshah@neoplastindia.com)  
(Director)

Ankit Shah +91-9825007220 / [ankitshah@neoplastindia.com](mailto:ankitshah@neoplastindia.com)  
(Director)



*Technic Pvt. Ltd.*

**Printed in INDIA**  
(Last Revised: Feb. 05, 2010)